

TRUCK CONVERSION ACCESSORIES

Many Lift Trucks can be Converted from Overhead Extraction to Side Extraction by Making Minor Modifications to the Side of the Lift Truck Battery Compartment. MTC Provides an Economic Solution, Offering Various Types of Slide Strips and Roller Trays.

Slide Strip Less Guide Roller

MODEL B-UPS-*

- UHMW Slide Strip. Height of B-UP from Base to Top of Slide Strip is 1". Unit Width is 1 1/8".
- (Requires Two to Three per Truck)
- Specify (*) Total Length with Roller
- Required at Time of Order

Slide Strip with Guide Roller

MODEL B-UPS-R*

- UHMW Slide Strip with Lead in Guide Roller. Height of B-UPS from Base to Top of Roller is 1 1/16". Unit Width is 2 1/8".
- (Requires Two to Three per Truck)
- Specify (*) Total Length with Roller
- Required at Time of Order

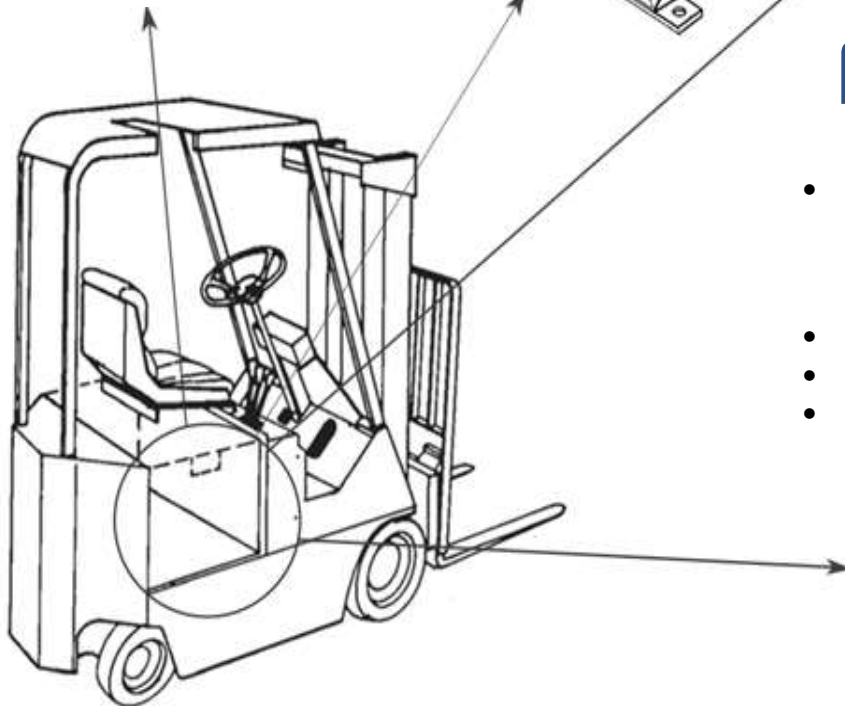
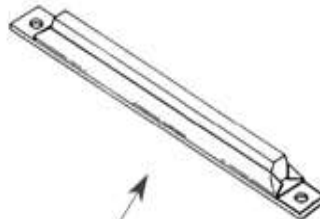
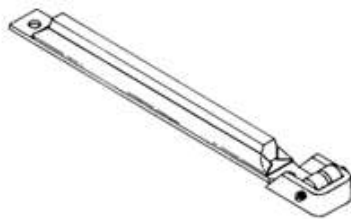

Battery Rollers

MODEL BR-HD

- Heavy Duty Battery Rollers Requires Customer Supplied 1 1/2" x 2 1/4" Cut Out in Truck Battery Compartment Base to Insert Rollers
- BR-HD Total Height is 1 1/32", Width is 3", & Depth is 2 1/16"
- (Requires Nine per Truck)

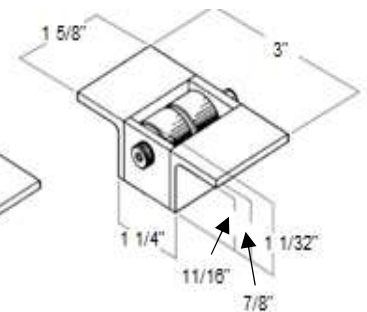

Heavy Duty Roller Tray

MODEL HRT-L-X

- Heavy Duty Battery Rollers Tray Build to Customer Specifications. Height of HRT from Base to Top of Roller is 1"
- "L" = Rail Length
- "X" = Number of Rails (Qty of 2 or 3)
- Specify Required Total Length ("L") and Total Width ("X") at Time of Order

